

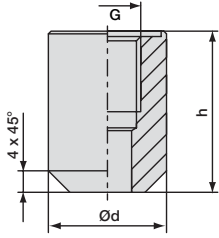

Special Adaptors Type SAS, SHA, SSV

Welding adaptor SAS



Thread G	Port connection	h		Ød		Order No. SAS
		mm	in	mm	in	
M10x1	Type A	25	0.98	20	0.79	SAS-M10x1
G ¹ / ₈	Type B/C	25	0.98	20	0.79	SAS-G ¹ / ₈
G ¹ / ₄		30	1.18	22	0.87	SAS-G ¹ / ₄
G ³ / ₈		30	1.18	25	0.98	SAS-G ³ / ₈
1/4NPT	Type D	25	0.98	20	0.79	SAS-1/4NPT
1/2-20UNF	Type E	25	0.98	20	0.79	SAS-1/2UNF

Material: St 37, black finished

TEST

Sampling Hose Adaptor-SHA

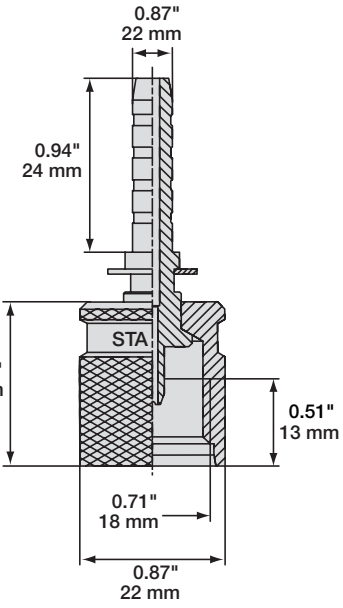

- Special Hose Adaptor for taking oil samples from Hydraulic Systems.
- Uses 1/4" O.D. Polyurethane Hose.
- Stauff Test 20 Connection
- Order No. SHA 20 - 5.5 mm

Union Adaptor SSV (for connecting 2 SMS Hoses)



Connection	Order Number
Stauff Test 20	SSV 20/20
Stauff Test 12	SSV 12/12
Stauff Test 15	SSV 15/15

